

768N

18,600 in.³ - NEW CONCEPT CART

MODEL	CAPACITY (in. ³)		NEST (in.)	WEIGHT (lbs.)	102X53' TRAILER	CHROME, NYLON BASKET	ONE COLOR POWDER	COMMENTS
	SHOPPING	BASKET				MULTICOLOR POWDER	OVER E-COAT	
768N	18,600	10,700	13 1/8	54	352	No	Yes	" Light " gate and wheels only moving parts

768N



768N (18,600 in.³)

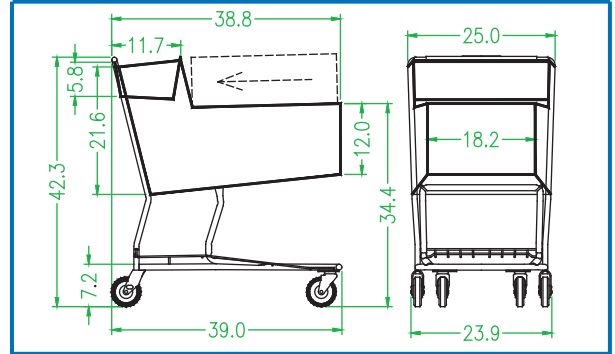

FEATURES

- Powder over E-coat - provides corrosion protection inside the tubing.
- Double wire truss basket - stronger, lighter.
- 7 ga. (0.177) rear casters - stronger, cleaner, self aligning.
- Integrated handle, rear casters, truss between rear wheels - much stronger.
- Extended base - much easier to load items on lower tray.
- Integrated 1" tube, 1/4 X 1 1/2 caster plates - much stronger, cleaner.
- Baby seat / small item compartment - twice as large, items less likely to fall through.
- Baby seat does not collapse - lighter, quieter.
- Seat belts last much longer.
- Accepts " deep " cup holder.
- Retrieval strap anchor - much easier and faster to secure a line of nested, carts together with a light / flexible strap without hooks.
- Accepts "bumper / caster lifts" - easier to maneuver line of nested carts, less wear on rear wheels, protects powder.
- Welded lower tray - lighter, quieter, protects powder.
- " Loops " on back rest to hang plastic bags.
- " Light " gate and wheels only moving parts.

Precision Wire Products, Inc.

COMMERCE, CALIFORNIA 99040 1 - 888 - 300 - 4PWP