

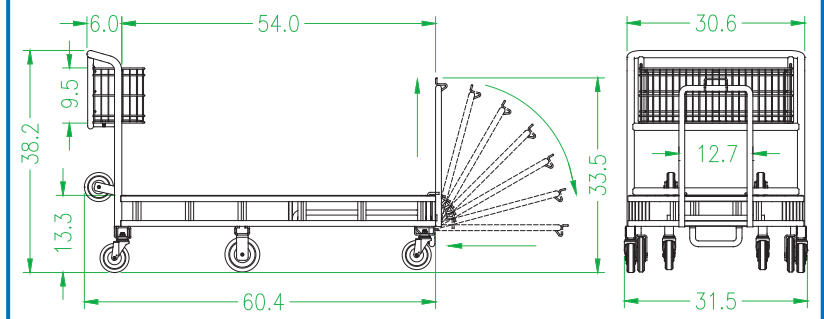

MODEL		608 P
TOTAL CAPACITY UP TO HANDLE HIGH	37,000 in ³	
BASKET CAPACITY	2,000 in ³	FINISH ONE COLOR POWDER OVER E-COAT
NESTING	25 3/4 in	
WEIGHT	106 lbs	
TRAILER CAPACITY 102 in X 53 ft	180 (with basket removed)	

FEATURES

- Six wheels - Shorter turn radius (4 swivel - 5" x 1.25", 2 rigid - 6" x 1.25").
- Nest to 25 3/4 in. - Stores in less space with better order.
- Caster lifts - Easier to maneuver a line of nested carts.
- Perforated deck for cleanliness.
- "Tuck - away" front stop.
- Flat deck - items less likely to slide off.



Precision Wire Products, Inc.

6150 SHEILA ST.
 COMMERCE, CALIFORNIA 90040 1 - 888 - 300 - 4PWP

MODEL NUMBER	NAME	DATE
608P	PLATFORM (Patented)	02/24/09