

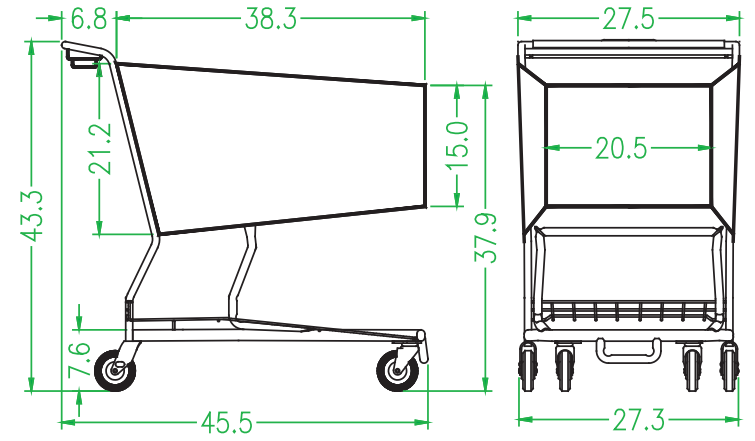

MODEL				
528 W				
TOTAL CAPACITY	23,200	in ³	FINISH	
BASKET CAPACITY	14,400	in ³		
NESTING	13 3/4	in		
WEIGHT	69	lbs		
TRAILER CAPACITY 102 in X 53 ft	252	shop. carts		
			CHROME, NYLON BASKET MULTICOLOR POWDER	NO
			ONE COLOR POWDER OVER E-COAT	YES

FEATURES

- Oval tube base - much stronger.
- Double wire truss basket - stronger, lighter.
- Drop down gravity assist baby seat - less likely to bind when nesting.
- 7 ga. (0.177) rear casters - stronger, cleaner, self aligning.
- Integrated handle, rear casters, truss between rear wheels - much stronger.
- Accepts convenience tray / cup holder.
- Powder over E-coat - provides corrosion protection inside the tubing.
- Integrated 1" tube, 1/4 X 1 1/2 caster plates - much stronger, cleaner.
- Accepts " bumper / caster lifts " - easier to maneuver line of nested carts, less wear on rear wheels, protects powder.
- Welded lower tray - lighter, quieter, protects powder.
- Double baby seat.
- Retrieval strap anchor - much easier and faster to secure a line of nested carts together with a light / flexible strap without hooks.
- Accepts fresh basket in front of basket.
- " Loops " on sides to hang plastic bags.
- Tubular bumper on base - protects front casters.



Precision Wire Products, Inc.

6150 SHEILA ST.
COMMERCE, CALIFORNIA 90040 1 - 888 - 300 - 4PWP

MODEL NUMBER	NAME	DATE
528W	SHOPPING CART	05/12/08