

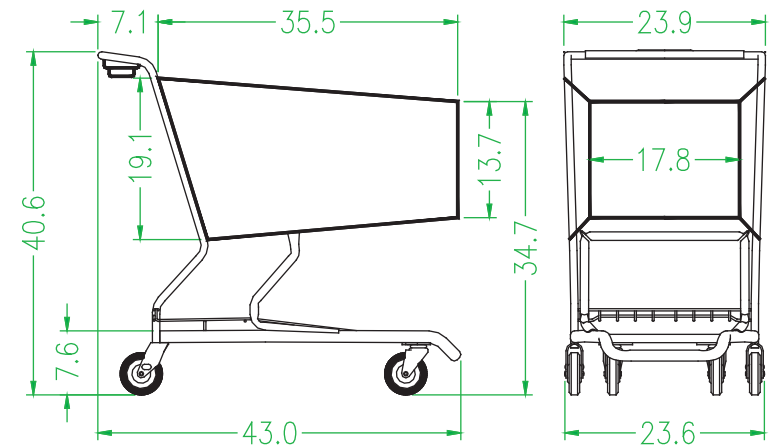

MODEL			
449 W			
TOTAL CAPACITY	15,800	in ³	FINISH
BASKET CAPACITY	10,200	in ³	
NESTING	12 1/2	in	CHROME, NYLON BASKET MULTICOLOR POWDER
WEIGHT	62	lbs	ONE COLOR POWDER OVER E-COAT
TRAILER CAPACITY	460	shop. carts	NO
102 in X 53 ft			YES

FEATURES

Oval tube base - much stronger.
 Powder over E-coat - provides corrosion protection inside the tubing.
 Double wire truss basket - stronger, lighter.
 Drop down gravity assist baby seat - less likely to bind when nesting.
 7 ga. (0.177) rear casters - stronger, cleaner, self aligning.
 Integrated handle, rear casters, truss between rear wheels - much stronger.
 Integrated 1" tube, 1/4 X 1 1/2 caster plates - much stronger, cleaner.
 Welded lower tray - lighter, quieter, protects powder.
 Accepts "bumper / caster lifts" - easier to maneuver line of nested carts, less wear on rear wheels, protects powder.
 Retrieval strap anchor - much easier and faster to secure a line of nested carts with a light / flexible strap without hooks.
 Accepts convenience tray / cup holder.
 Accepts fresh basket in front of basket.



Precision Wire Products, Inc.

6150 SHEILA ST.
 COMMERCE, CALIFORNIA 90040 1 - 888 - 300 - 4PWP

MODEL NUMBER
449W

NAME
SHOPPING CART

DATE
 05/01/08