

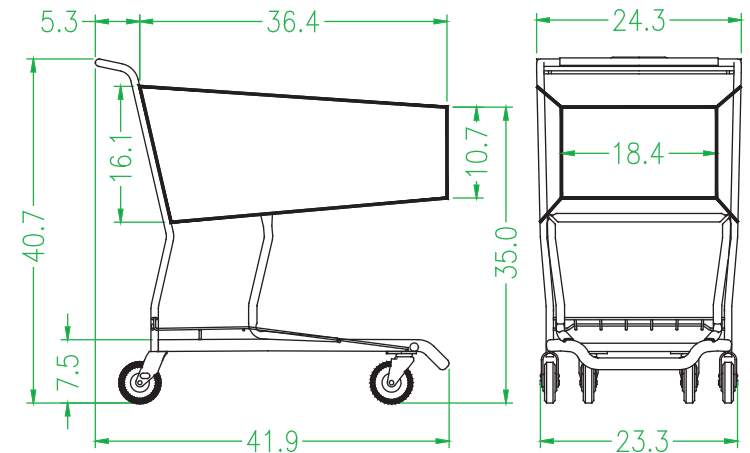

MODEL									
424 W									
TOTAL CAPACITY	17,200	in ³	<table border="1"> <thead> <tr> <th colspan="2">FINISH</th> </tr> </thead> <tbody> <tr> <td>CHROME, NYLON BASKET MULTICOLOR POWDER</td> <td>NO</td> </tr> <tr> <td>ONE COLOR POWDER OVER E-COAT</td> <td>YES</td> </tr> </tbody> </table>	FINISH		CHROME, NYLON BASKET MULTICOLOR POWDER	NO	ONE COLOR POWDER OVER E-COAT	YES
FINISH									
CHROME, NYLON BASKET MULTICOLOR POWDER	NO								
ONE COLOR POWDER OVER E-COAT	YES								
BASKET CAPACITY	9,100	in ³							
NESTING	12 1/2	in							
WEIGHT	55	lbs							
TRAILER CAPACITY 102 in X 53 ft	460	shop. carts							

FEATURES

Oval tube base - much stronger.
 Powder over E-coat - provides corrosion protection inside the tubing.
 Integrated 1" tube, 1/4 X 1 1/2 caster plates - much stronger, cleaner.
 Double wire truss basket - stronger, lighter.
 Drop down gravity assist baby seat - less likely to bind when nesting.
 7 ga. (0.177) rear casters - stronger, cleaner, self aligning.
 Integrated handle, rear casters, truss between rear wheels - much stronger.
 Accepts "bumper / caster lifts" - easier to maneuver line of nested carts, less wear on rear wheels, protects powder.
 Welded lower tray - lighter, quieter, protects powder.



Precision Wire Products, Inc.

6150 SHEILA ST.
 COMMERCE, CALIFORNIA 90040 1 - 888 - 300 - 4PWP

MODEL NUMBER
424W

NAME
SHOPPING CART

DATE
 05/01/08